



**VERTIKON**

VERTICAL SMALL WIND TURBINES

**THE ENERGY SOURCE OF THE FUTURE**

**WHEN THE WIND OF  
CHANGE BLOWS,  
SOME PEOPLE BUILD  
WALLS, WHILE OTHERS  
BUILD WINDMILLS.**

CHINESE PROVERB

### THE NEW INDEPENDENCE FROM VERTICAL SMALL WIND TURBINES

Do you already use sustainably produced energy, and would like to take an active part in the energy revolution? Why not simply generate your own green energy? Do you still use conventional power for yourself and your company? If so, producing your own electricity is an alternative, allowing you to become independent from increasing energy costs and unsustainable resources.

### VERTIKON IS YOUR ALTERNATIVE AND YOUR ENERGY SOURCE FOR THE FUTURE

Our high-performance small wind turbines use the wind from all directions and even at low wind strengths develop a very high degree of efficiency. You can use this self-generated electricity to cover your own needs, or feed it into the public grid.

Just as you become independent from the energy market, you can also freely choose the installation site of the wind turbine. The type and variable turbine height make it possible to mount it on house roofs, terraces, hall roofs and silos, for example.

However, our low-noise turbines are also particularly suitable for self-sufficient supply to remote consumers in the private and commercial sector.

SELF-CONTAINED  
AND  
SELF-SUFFICIENT



## TOP-QUALITY TECHNOLOGY FOR ENERGY GENERATION

The rotor blades of the VERTIKON small wind turbines are made of fibreglass-reinforced plastic and are equipped with a lotus effect. With their high level of quality, all turbine parts are designed with a long service life in mind. The excellent aerodynamics of the rotors guarantee an early start-up, and therefore also maximum energy yields. The control electronics have been specially developed for the VERTIKON systems. The hybrid inverter used enables additional connection to photovoltaic systems. The integrated safety system makes our turbines even more stable: it allows problem-free operation even at low wind levels, and ensures that the turbine runs safely during high winds.

These high-quality individual components make this a safe investment for you, as well as ensuring a high degree of weather resistance and particularly long maintenance intervals. Every wind turbine produced by us is thoroughly examined and tested in a test procedure to ensure that its full range of functions are in order before being dispatched.

### VERTIKON M/Basis – summary of technical specifications

FEED-IN CAPACITY, WIND ENERGY	
Capacity at 11 m/s	950 W
Capacity at 5 m/s	80 W
Max. capacity 14–16 m/s	1,700 W
Start-up speed	3 m/s
Shutdown speed	16 m/s
ROTOR GEOMETRY	
Rotor diameter	2.4 m
Rotor height	2.4 m
Rotor surface area	5.8 m <sup>2</sup>
Number of rotor blades	3
GRID STRUCTURE, GENERATOR SIDE	
Grid	IT system
Generator	3P synchronous generator
Rated voltage	400 V <sub>effLL3</sub>
Rated frequency	50 Hz
Rated capacity	1.2 kW
TURBINE CONTROL AND BRAKING SYSTEM	
Rotation speed restriction with load resistance	
Redundant brake via generator short-circuit	
Automatic shutdown during stormy weather (> 16 m/s)	
Automatic shutdown with turbine error	
FEEDING INTO THE ELECTRICITY GRID	
Hybrid inverter	Ginlong GCI-2K-H
Feed-in capacity	Max. 2,000 W
Output voltage (AC)	230 V, single-phase
ENS anti-islanding device as per E DIN VDE 0126	Integrated
TURBINE TOWER	
Type	Pipe pylon without bracing
Tower heights	6 m, 12 m or 18 m
ANNUAL YIELDS	
At 4 m/s (k = 1.8)	1,040 kWh
At 5 m/s (k = 2.0)	1,800 kWh
At 6 m/s (k = 2.2)	2,800 kWh

### VERTIKON M/PV-plus – summary of technical specifications

WIND			
<b>Feed-in capacity, wind energy</b>			
Capacity at 11 m/s	950 W		
Capacity at 5 m/s	80 W		
Max. capacity 14–16 m/s	1,700 W		
Start-up speed	3 m/s		
Shutdown speed	16 m/s		
ROTOR GEOMETRY			
Rotor diameter	2.4 m		
Rotor height	2.4 m		
Rotor surface area	5.8 m <sup>2</sup>		
Number of rotor blades	3		
GRID STRUCTURE, GENERATOR SIDE			
Grid	IT system		
Generator	3P synchronous generator		
Rated voltage	100 V <sub>effLL</sub>		
Rated frequency	50 Hz		
Rated capacity	1.2 kW		
TURBINE CONTROL AND BRAKING SYSTEM			
Rotation speed restriction with load resistance			
Redundant brake via generator short-circuit			
Automatic shutdown during stormy weather (> 16 m/s)			
Automatic shutdown with turbine error			
FEEDING INTO THE ELECTRICITY GRID			
Hybrid inverter	Ginlong GCI-2K-H		
Feed-in capacity	Max. 2,000 W		
Output voltage (AC)	230 V, single-phase		
ENS anti-islanding device as per E DIN VDE 0126	Integrated		
TURBINE TOWER			
Type	Pipe pylon without		
Tower heights	6 m, 12 m or 18 m		
ANNUAL YIELDS:			
	WIND	SOLAR	TOTAL
At 4 m/s (k = 1.8)	1,040 kWh	300 kWh	1,340 kWh
At 5 m/s (k = 2.0)	1,800 kWh	300 kWh	2,100 kWh
At 6 m/s (k = 2.2)	2,800 kWh	300 kWh	3,100 kWh

SOLAR	
<b>Feed-in capacity, solar energy</b>	
Total capacity	300 Wp
SOLAR MODULES (x 2)	
Dimensions	1,642 x 992 mm
Module voltage	29,3 V
Module capacity	240 Wp
GRID STRUCTURE, MODULE SIDE	
Grid	IT system
Voltage type	DC voltage
Connection	Series connection
Rated voltage	
Rated capacity	



### VERTIKON M/BL – summary of technical specifications

LOAD CAPACITY, WIND ENERGY	
Capacity at 7 m/s	230 W
Capacity at 4 m/s	36 W
Max. capacity 7,5–12 m/s	300 W
Start-up speed	3 m/s
Shutdown speed	12 m/s
ROTOR GEOMETRY	
Rotor diameter	2.4 m
Rotor height	2.4 m
Rotor surface area	5.8 m <sup>2</sup>
Number of rotor blades	3
GRID STRUCTURE, GENERATOR SIDE	
Grid	IT system
Generator	3P synchronous generator
Rated voltage	100 V <sub>effLL</sub>
Rated frequency	50 Hz
Rated capacity	0.3 kW
TURBINE CONTROL AND BRAKING SYSTEM	
Rotation speed restriction with load resistance	
Redundant brake via generator short-circuit	
Automatic shutdown during stormy weather (>12 m/s)	
Automatic shutdown with turbine error	
CHARGE CONTROLLER	
Battery system voltage	24 V
Battery types	Lead-acid (wet, gel, AGM)
Charge capacity	300 W (max. 12.5 A)
LCD display	U, I, P
Standby consumption	<0.5 W
Efficiency	>90 %
IP protection class	IP64
TURBINE TOWER	
Type	Pipe pylon without bracing
Tower heights	6 m, 12 m or 18 m
ANNUAL YIELDS	
At 4 m/s (k = 1.8)	31,000 Ah
At 5 m/s (k = 2.0)	45,000 Ah
At 6 m/s (k = 2.2)	56,000 Ah

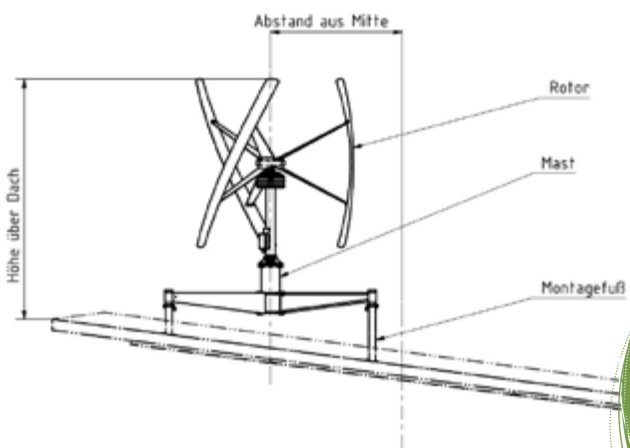
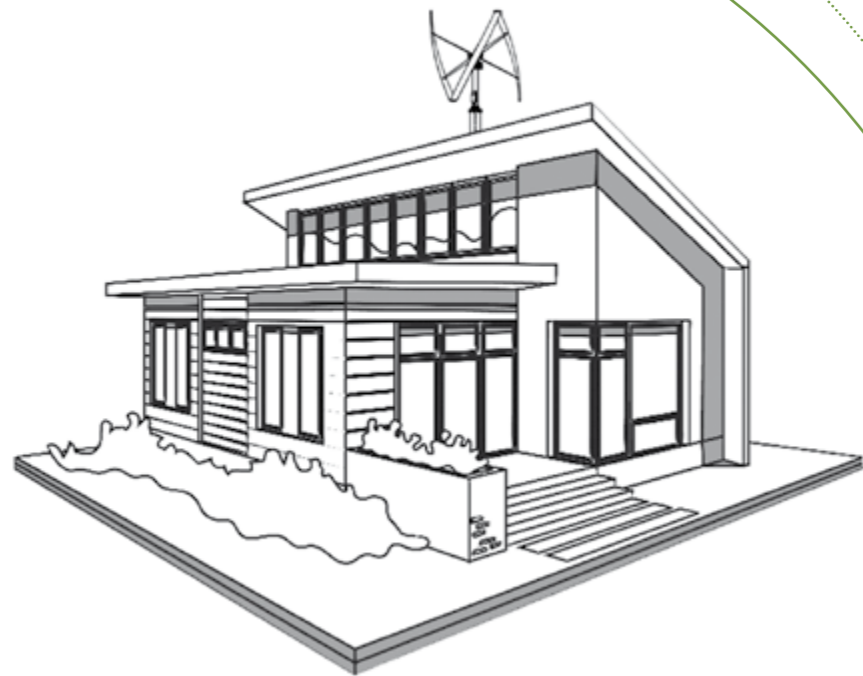

**FREE OF  
OSCILLATIONS AND  
VIBRATIONS**

## GENERATE ELECTRICITY ON YOUR OWN ROOF

Thanks to the use of the newly-developed decoupler, we can also offer you special superstructures for areas independently of roof and mast types. The vibration decoupler has been adapted to the VERTIKON turbines and decouples the wind turbines from the substructure. As a result, no more vibrations are transmitted onto the building, and dynamic loads are kept to a minimum.

Whether you plan to mount your turbine on the ground, roof or on a mast, we offer innovative solutions and close cooperation with our structural engineers. You don't need to decide on the mast height right at the start. You can choose to adapt it to your energy yields if you wish. This means that you can start right away with a 6 m mast, and extend your system to 12 or even 18 m with no complex procedure involved.

## AUXILIARY SERVICES

Battery  
Special solutions  
Mast segment 6 m

Adapted to your own capacity requirements  
Roof superstructures, special masts including structural calculation  
Designed for extension to 12 m and 18 m, hot-galvanised, including structural calculation and connecting elements

Packaging  
Transportation  
Mounting  
Visual appearance

Stable and ready for transportation  
In regions accessible by lorry  
Assembly and installation by trained personnel  
Turbines available in your chosen colour (RAL colours)  
Application of a logo

## STANDARD ACCESSORIES

GinLong 2 kW hybrid inverter  
Safety electronics  
System control  
Wind measurement system, including system evaluation  
Vibration decoupler  
Mast system, 6 m, including anchor cage and structural calculation

**THE RIGHT SOLUTION  
FOR ALL  
REQUIREMENTS**



## Sales

DeTec Vision GmbH

Rüdigsdorfer Weg 10

99734 Nordhausen/OT Petersdorf

Germany

Phone 0 049 3631 4659261

Fax 0 049 3631 4659262

info@detec-vision.de

www.detc-vision.de

facebook.com/Vertikon - vertikale Kleinwindkraftanlagen



### Legal notice:

DeTec Vision GmbH, Sylvia Lauerwald

Tormühle | Zwischen den Toren 2, DE-99755 Ellrich

www.detc-vision.de

Design: LANDSIEDEL | MÜLLER | FLAGMEYER www.l-m-f.de

Image credits: www.webdesign-gassner.de, www.fotolia.com,

www.istockphoto.com

11.2015 Subject to errors and technical modifications. All

trademarks listed are the property of their respective owners.

Member of:



# VERTIKON

## VERTICAL SMALL WIND TURBINES

For enquiries please contact: